

Part number:

HYDROMA

HYDRAULICKÉ SYSTÉMY

**HIDROMA
SISTEMS**

UKŁADY HYDRAULICZNE

HYDROMA

ГИДРАВЛИЧЕСКИЕ СИСТЕМЫ

Single counterbalance, relief compensated

A-VBSO-SE-CC-30

08.43.96 - X - Y - Z

RE 18307-47

Edition: 03.2016

Replaces: 04.2010



Technical data

Max. operating pressure	410 bar (5945 psi)
Max. flow	60 l/min. (16 gpm)
Weight	see "Dimensions"
Manifold material	Zinc plated steel
Fluid	Mineral oil (HL, HLP) according DIN 51524
Fluid temperature range	-30 °C to 100 (-22 to 212 °F)
Viscosity range	5 to 800 mm ² /s (cSt)
Recommended degree of fluid contamination	Class 19/17/14 according to ISO 4406
MTTFd	150 years see data sheet 18350-51
Other technical data	see data sheet 18350-50
Relief setting: at least 1.3 times the highest expected load.	

Note: for applications outside these parameters, please consult us.

Description

When pressure at V2 rises above the spring bias pressure, the check seat is pushed away from the piston and flow is allowed from V2 to C2. When load pressure at C2 rises above the setting, the direct-acting relief function is activated and flow is relieved from C2 to V2. With pilot pressure at Pil, the pressure setting is reduced in proportion to the stated ratio, until opening and allowing flow from C2 to V2. The spring chamber is drained to V2. The valve applies a balanced piston allowing relief at the valve setting independent of back-pressure at V2. However, the piloted opening of the valve remains subject to additive pressure at port V2.

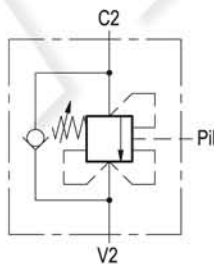

Characteristic curve

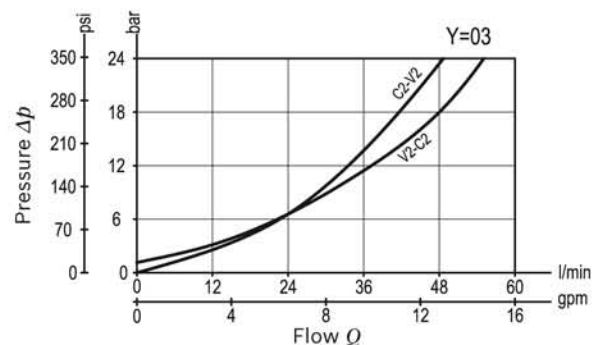

Ordering code

08.43.96	X	Y	Z
-----------------	----------	----------	----------

Single counterbalance,
relief compensated

Pilot ratio

03 4.2 : 1

Port sizes	V2	C2	Pil
02	G 3/8	G 3/8	G 3/8
03	G 1/2	G 1/2	G 1/4

	SPRINGS		
	Adj. pressure range bar (psi)	Pres. increase bar/turn (psi/turn)	Std. setting Q=5 (l/min) bar (psi)
20	60-210 (870-3000)	75 (1088)	200 (2900)
35	100-350 (1450-5000)	165 (2393)	350 (5000)

Pressure setting up to 410 bar: code on request.

Tamper resistant cap code
ordering code 11.04.23.003
Mat. no. R930000754



Preferred types

Type	Material number
08439603022000A	R930007270
08439603023500A	R930007271
08439603032000A	R930007272
08439603033500A	R930007273

Type	Material number

Dimensions

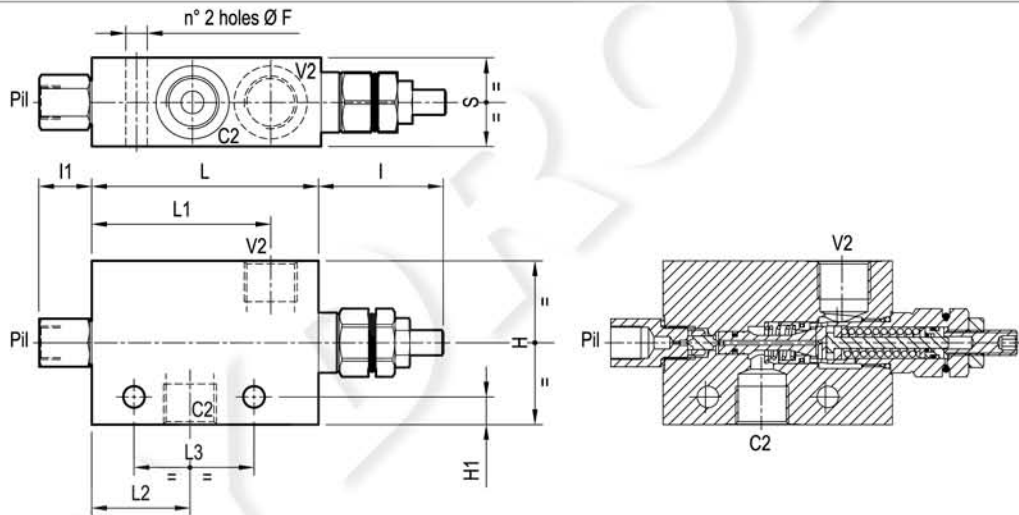

35	47.6	39.3	70.3	91	21	49.5	11	65		8.5			G 1/2	1.55
(1.38)	(1.87)	(1.55)	(2.77)	(3.58)	(0.83)	(1.95)	(0.43)	(2.56)		(0.34)				(3.42)
30	47.6	39.3	70.3	91	21	49.5	7	55		8.5			G 3/8	1.15
(1.18)	(1.87)	(1.55)	(2.77)	(3.58)	(0.83)	(1.95)	(0.28)	(2.17)		(0.34)				(2.54)
S	L3	L2	L1	L	I1	I	H1	H		F			Y	Weight
														kg (lbs)