

Part number:

Check Valves - RV Series

Specifications

- Sizes to 2"
- Carbon Steel Body, Zinc Plated
- Working Pressure to 7250 PSI (500 bar)
- Metal to Metal Seat

Options

- NPT or SAE
- Two Spring Cracking Pressures - 7 PSI (0.5 bar) or 65 PSI (4.5 bar)
- Special Spring Cracking Pressures Available On Request
- Stainless Steel construction

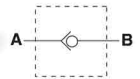

Dimensional Information

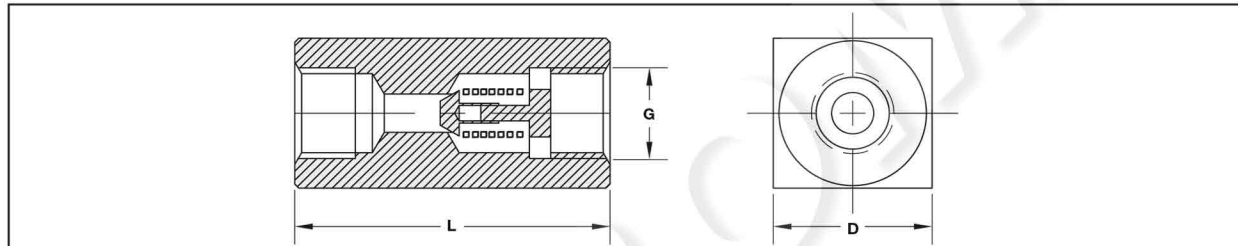

Nominal Size	DN		Port G		Operating Pressure		D		L		Weight	
	mm	in	NPT	SAE	Bar	PSI	mm	in	mm	in	kg	lbs
RV8	8	0.31	1/4" NPT	7/16"-20	500	7250	25	.98	55	2.17	0.2	0.44
RV10	10	0.39	3/8" NPT	9/16"-18	500	7250	30	1.18	65	2.56	0.4	0.88
RV12	12	0.47	1/2" NPT	3/4"-16	500	7250	35	1.38	73	2.87	0.7	1.54
RV16	16	0.63	3/4" NPT	1 1/16"-12	500	7250	45	1.77	88	3.46	1.2	2.64
RV20	20	0.79	1" NPT	1 5/16"-12	500	7250	50	1.97	127	5.00	2	4.4
RV25	25	0.98	1 1/4" NPT	1 5/8"-12	400	5800	60	2.36	143	5.63	3.3	7.26
RV30	30	1.18	1 1/2" NPT	1 7/8"-12	315	4500	70	2.75	143	5.63	4.2	9.24
RV40	40	1.57	2" NPT	2 1/2"-12	315	4500	90	3.54	165	6.49	7.2	15.84

Ordering Information

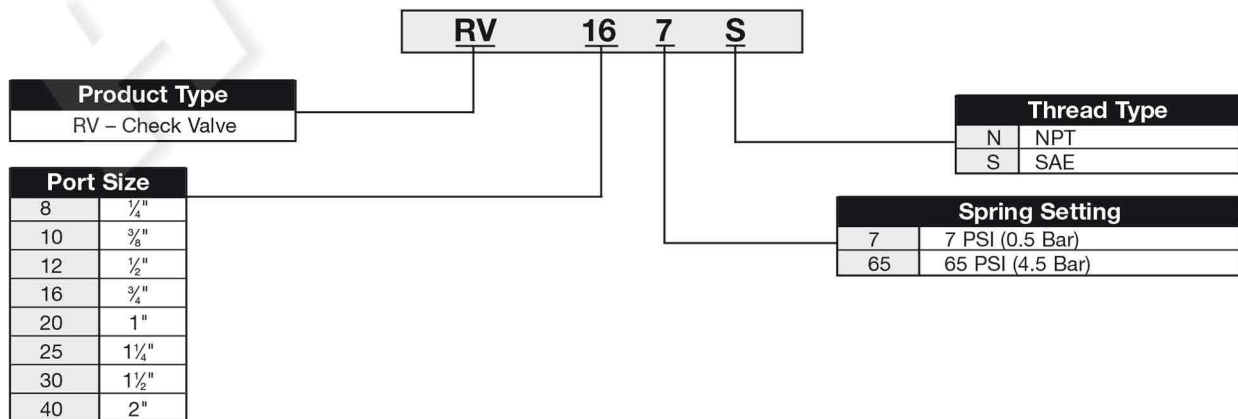

VALVES