

Part number:

**HYDROMA**

HYDRAULICKÉ SYSTÉMY

**HIDROMA  
SISTEMS**

UKŁADY HYDRAULICZNE

**HYDROMA**

ГИДРАВЛИЧЕСКИЕ СИСТЕМЫ

## HYDRAULIC MOTORS MR



### APPLICATION

- » Conveyors
- » Feeding mechanism of robots and manipulators
- » Metal working machines
- » Textile machines
- » Agricultural machines
- » Food industries
- » Grass cutting machinery etc.

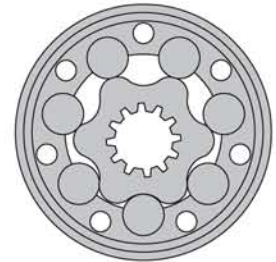

### CONTENTS

Specification data  
Function diagrams  
Dimensions and mounting  
Shaft extensions  
Permissible shaft loads  
Permissible shaft Seal Pressure  
Order code

### OPTIONS

- » Model - Spool valve, roll-gerotor
- » Flange mount
- » Motor with needle bearing
- » Side and rear ports
- » Shafts - straight, splined and tapered
- » Shaft seal for high and low pressure
- » Metric and BSPP ports
- » Speed sensing
- » Other special features

### GENERAL

Max. Displacement,	cm <sup>3</sup> /rev [in <sup>3</sup> /rev]	397 [24.4]
Max. Speed,	[RPM]	970
Max. Torque,	daNm [lb-in]	cont.: 61 [5400] int.: 69 [6100]
Max. Output,	kW [HP]	15 [20.1]
Max. Pressure Drop,	bar [PSI]	cont.: 175 [2540] int.: 200 [2900]
Max. Oil Flow,	lpm [GPM]	75 [20]
Min. Speed,	[RPM]	10
Pressure fluid		Mineral based- HLP (DIN 51524) or HM (ISO 6743/4)
Temperature range,	°C [°F]	-40÷140 [-40÷284]
Optimal Viscosity range,	mm <sup>2</sup> /s [SUS]	20÷75 [98÷347]
Filtration		ISO code: 18/16/13 According to ISO 4406-1999

#### Oil flow in drain line

Pressure drop bar [PSI]	Viscosity mm <sup>2</sup> /s [SUS]	Oil flow in drain line lpm [GPM]
100 [1450]	20 [98]	2,5 [.660]
	35 [164]	1,8 [.476]
140 [2030]	20 [98]	3,5 [.925]
	35 [164]	2,8 [.740]

#### Pressure Losses

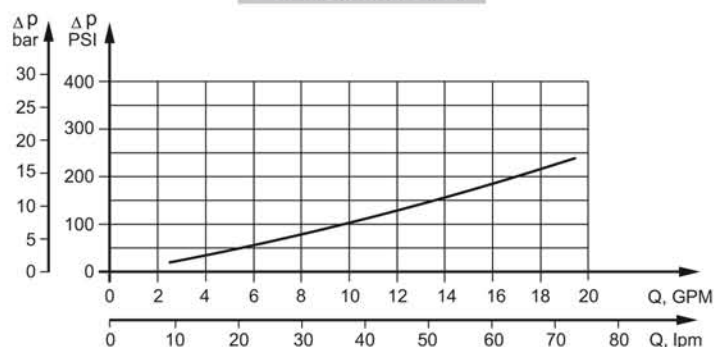

## SPECIFICATION DATA

Specification Data for MR... motors with **C, CO, SH, K** and **SA** shafts.  
( $\varnothing 28,56$  sealing diameter)

Type	MR 50	MR 80	MR 100	MR 125	MR 160	MR 200	MR 250	MR 315	MR 400	
Displacement, cm <sup>3</sup> /rev [in <sup>3</sup> /rev ]	51,5 [3.14]	80,3 [4.90]	99,8 [6.09]	125,7 [7.67]	159,6 [9.74]	199,8 [12.19]	250,1 [15.26]	315,7 [19.26]	397 [24.4]	
Max. Speed, [RPM]	Cont.	775	750	600	475	375	300	240	190	
	Int.*	970	940	750	600	470	375	300	240	
Max. Torque daNm [lb-in]	Cont.	10 [900]	20 [1770]	24 [2125]	30 [2655]	39 [3450]	38,5 [3410]	39 [3450]	36 [3185]	38 [3360]
	Int.*	13 [1150]	22 [1947]	28 [2480]	34 [3010]	43 [3805]	46 [4070]	47 [4160]	47 [4160]	47 [4160]
	Peak**	17 [1505]	27 [2390]	32 [2832]	37 [3275]	46 [4070]	56 [4960]	60 [5310]	61 [5400]	61 [5400]
Max. Output kW [HP]	Cont.	7 [9.5]	12,5 [17]	13 [17.4]	12,5 [16.8]	11,5 [15.4]	9 [12]	8 [10.7]	5 [6.7]	4,8 [6.4]
	Int.*	8,5 [11.9]	15 [20.1]	15 [20.1]	14,5 [19.5]	14 [18.8]	12 [16.1]	9,5 [12.7]	8 [10.7]	6,8 [9.1]
Max. Pressure Drop bar [PSI]	Cont.	140 [2030]	175 [2540]	175 [2540]	175 [2540]	175 [2540]	140 [2030]	110 [1600]	85 [1230]	65 [940]
	Int.*	175 [2540]	200 [2900]	200 [2900]	200 [2900]	200 [2900]	175 [2540]	140 [2030]	115 [1670]	90 [1300]
	Peak**	225 [3260]	225 [3260]	225 [3260]	225 [3260]	225 [3260]	225 [3260]	200 [2900]	150 [2175]	115 [1670]
Max. Oil Flow lpm [GPM]	Cont.	40 [10.5]	60 [15.8]	60 [15.8]	60 [15.8]	60 [15.8]	60 [15.8]	60 [15.8]	60 [15.8]	60 [15.8]
	Int.*	50 [13.2]	75 [19.8]	75 [19.8]	75 [19.8]	75 [19.8]	75 [19.8]	75 [19.8]	75 [19.8]	75 [19.8]
Max. Inlet Pressure bar [PSI]	Cont.	175 [2540]	175 [2540]	175 [2540]	175 [2540]	175 [2540]	175 [2540]	175 [2540]	175 [2540]	175 [2540]
	Int.*	200 [2900]	200 [2900]	200 [2900]	200 [2900]	200 [2900]	200 [2900]	200 [2900]	200 [2900]	200 [2900]
	Peak**	225 [3260]	225 [3260]	225 [3260]	225 [3260]	225 [3260]	225 [3260]	225 [3260]	225 [3260]	225 [3260]
Max. Return Pres- sure with Drain Line bar [PSI]	Cont.	175 [2540]	175 [2540]	175 [2540]	175 [2540]	175 [2540]	175 [2540]	175 [2540]	175 [2540]	175 [2540]
	Int.*	200 [2900]	200 [2900]	200 [2900]	200 [2900]	200 [2900]	200 [2900]	200 [2900]	200 [2900]	200 [2900]
	Peak**	225 [3260]	225 [3260]	225 [3260]	225 [3260]	225 [3260]	225 [3260]	225 [3260]	225 [3260]	225 [3260]
Max. Starting Pressure with Unloaded Shaft, bar [PSI]		10 [145]	10 [145]	10 [145]	9 [130]	7 [102]	5 [73]	4 [58]	3 [44]	3 [44]
Min. Starting Torque daNm [lb-in]	At max.press. drop Cont.	8 [710]	15 [1330]	20 [1770]	25 [2215]	32 2832]	33 [2920]	31 [2740]	31,5 [2875]	31,5 [2875]
	At max.press. drop Int.*	10 [885]	17 [1505]	23 [2035]	28 [2480]	37 [3275]	40 [3540]	48 [4250]	58 [5220]	50 [4425]
Min. Speed***, [RPM]		10	10	10	10	10	10	10	10	
Weight, kg [lb]	MR(F)	6,8 [15]	6,9 [15.2]	7,2 [15.9]	7,3 [16.1]	7,5 [15.2]	8 [17.6]	8,4 [18.5]	9,1 [20]	9,8 [21.6]
For rear ports: +0,650 [1.433]	MRQ(N)	6,2 [13.7]	6,3 [13.9]	6,6 [14.6]	6,8 [15]	7,2 [14.7]	7,6 [15.4]	7,8 [17.2]	8,6 [19]	9,3 [20.5]

\* Intermittent operation: the permissible values may occur for max. 10% of every minute.

\*\* Peak load: the permissible values may occur for max. 1% of every minute.

\*\*\* For speeds lower than given, consult factory or your regional manager.

- Intermittent speed and intermittent pressure must not occur simultaneously.
- Recommended filtration is per ISO cleanliness code 20/16. A nominal filtration of 25 micron or better.
- Recommend using a premium quality, anti-wear type mineral based hydraulic oil HLP(DIN51524) or HM ( ISO 6743/4).  
If using synthetic fluids consult the factory for alternative seal materials.
- Recommended minimum oil viscosity 13 mm<sup>2</sup>/s [70 SUS] at 50°C [122°F].
- Recommended maximum system operating temperature is 82°C [180°F].
- To assure optimum motor life fill with fluid prior to loading and run at moderate load and speed for 10-15 minutes.

**FUNCTION DIAGRAMS**

**MR 250**

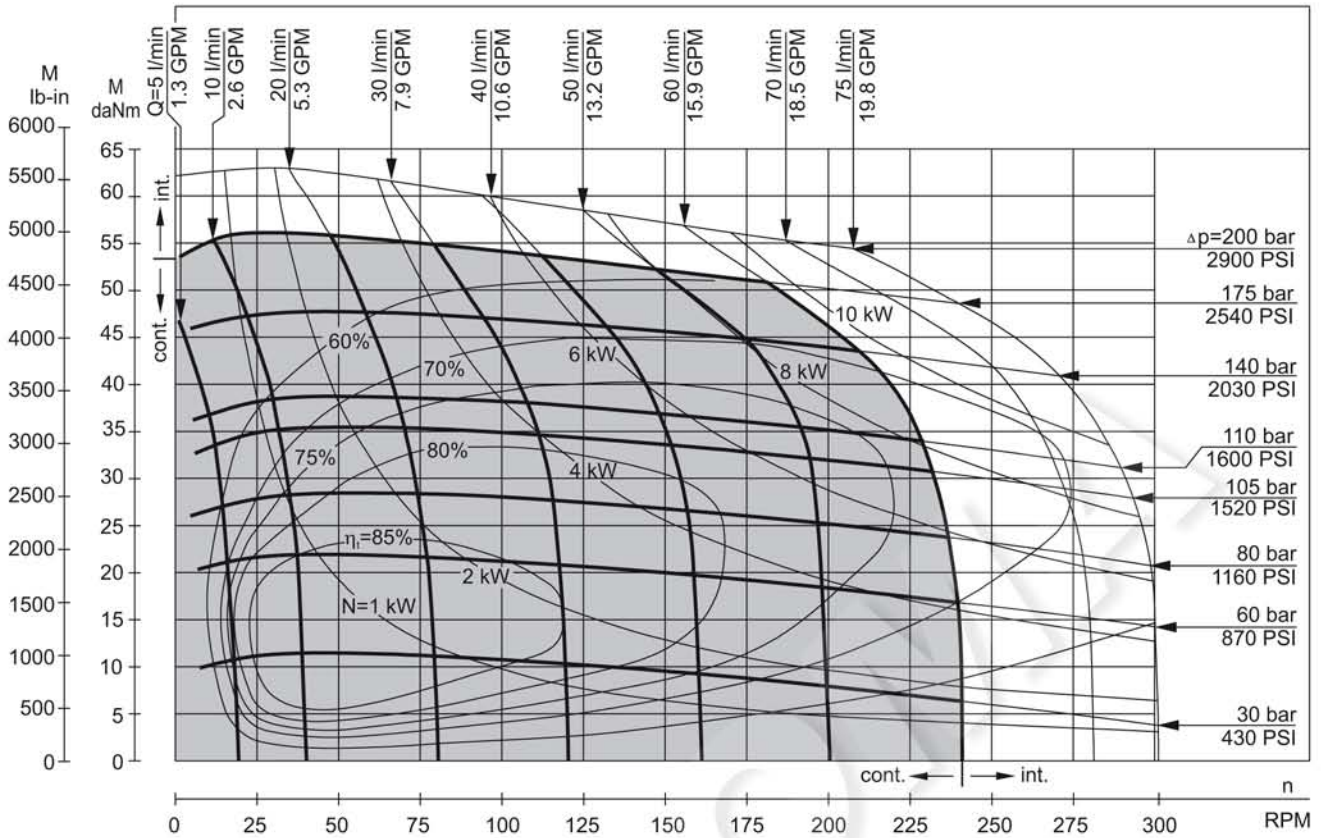

**MR 315**

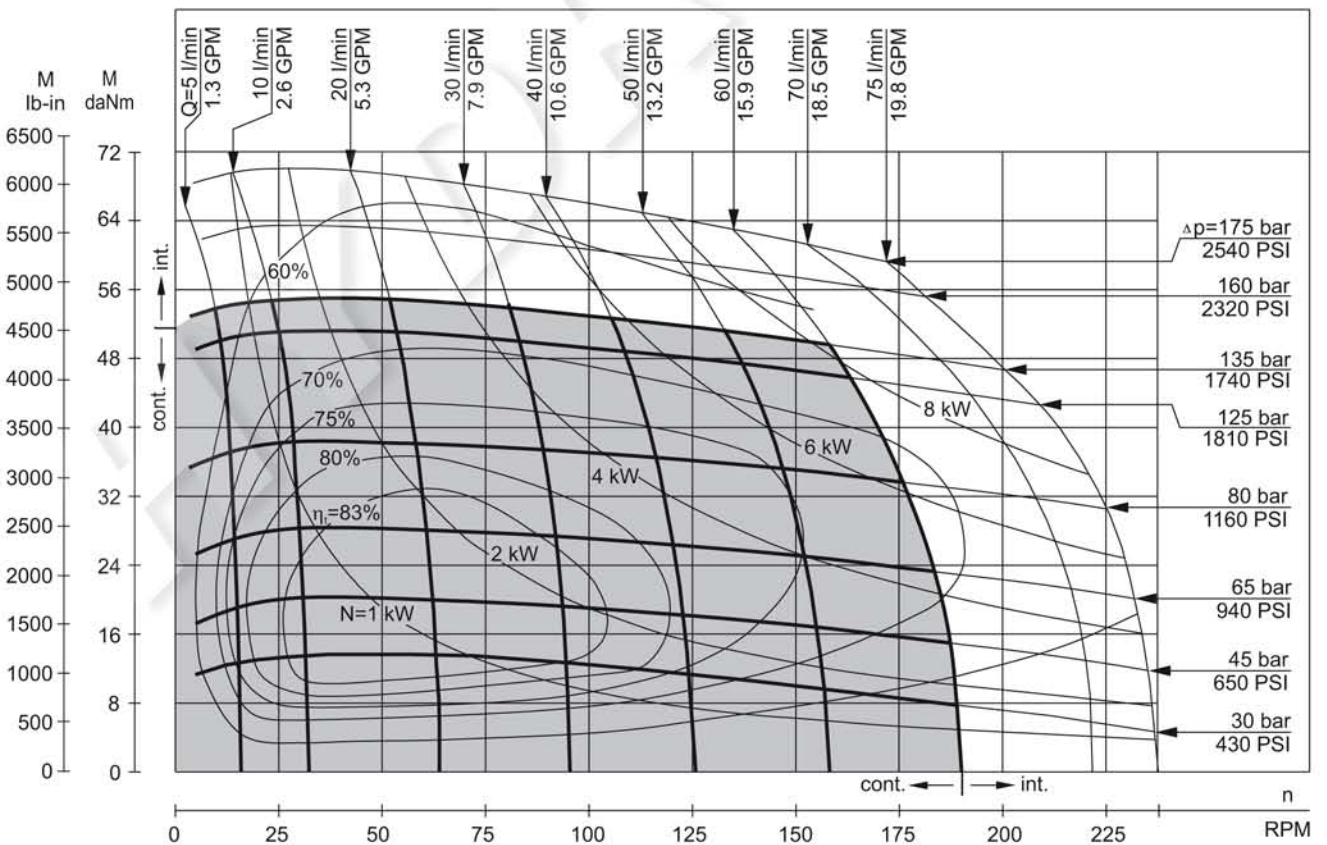

The function diagrams data is for average performance of randomly selected motors at back pressure 5÷10 bar [72.5÷145 PSI] and oil with viscosity of 32 mm<sup>2</sup>/s [150 SUS] at 50°C [122°F].

**DIMENSIONS AND MOUNTING DATA**

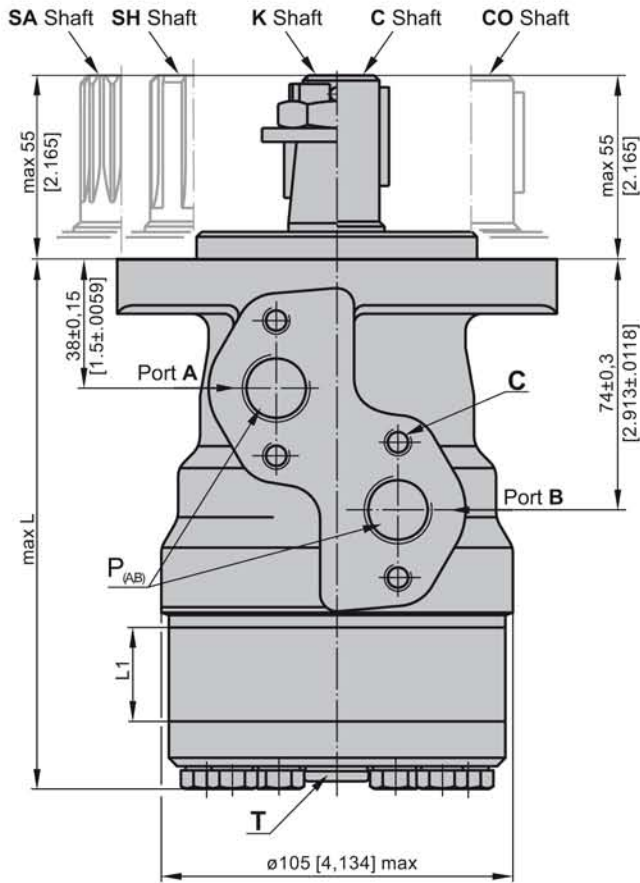

Shaft Dim.  
See Page 28

Flange Dim.  
See Page 41

Port Dim.  
See Page 41

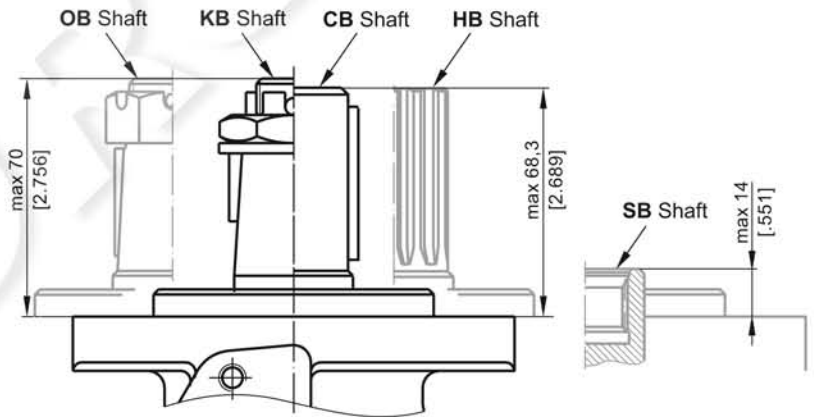
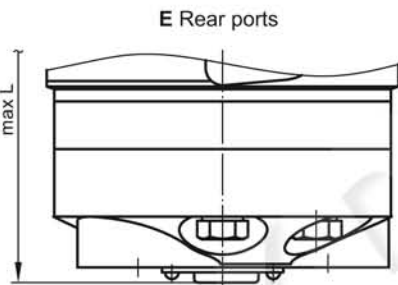
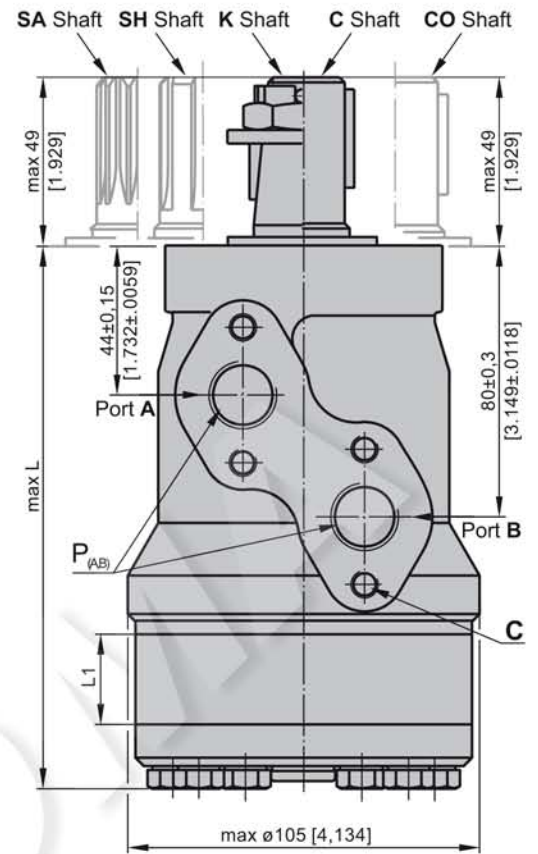

- C** : 4xM8 - 13 mm [.51 in] depth
- P<sub>(A,B)</sub>** : 2xG1/2 or 2xM22x1,5 - 15 mm [.59 in] depth
- T** : G1/4 or M14x1,5 - 12 mm [.47 in] depth (plugged)

- |  |   |
|--|---|
| <b>Standard Rotation</b><br>Viewed from Shaft End<br>Port A Pressurized - <b>CW</b><br>Port B Pressurized - <b>CCW</b> | <b>Reverse Rotation</b><br>Viewed from Shaft End<br>Port A Pressurized - <b>CCW</b><br>Port B Pressurized - <b>CW</b> |
|--|---|

Type	L, mm [in]	Type	L, mm [in]	Type	L, mm [in]	Type	L, mm [in]	L <sub>r</sub> , mm [in]
MR(F) 50	138,0 [5.43]	MRQ 50	143,5 [5.65]	MR(F)E 50	157,5 [6.20]	MRQE 50	163,5 [6.44]	9,0 [.35]
MR(F) 80	143,0 [5.63]	MRQ 80	148,5 [5.85]	MR(F)E 80	162,5 [6.40]	MRQE 80	168,5 [6.63]	14,0 [.55]
MR(F) 100	146,0 [5.75]	MRQ 100	152,0 [5.98]	MR(F)E 100	165,5 [6.52]	MRQE 100	171,5 [6.75]	17,4 [.69]
MR(F) 125	150,5 [5.93]	MRQ 125	156,5 [6.16]	MR(F)E 125	170,0 [6.69]	MRQE 125	176,0 [6.93]	21,8 [.86]
MR(F) 160	156,5 [6.16]	MRQ 160	162,5 [6.40]	MR(F)E 160	176,0 [6.93]	MRQE 160	182,0 [7.17]	27,8 [1.09]
MR(F) 200	163,5 [6.44]	MRQ 200	169,5 [6.67]	MR(F)E 200	183,0 [7.20]	MRQE 200	189,0 [7.44]	34,8 [1.37]
MR(F) 250	172,0 [6.77]	MRQ 250	179,0 [7.05]	MR(F)E 250	192,0 [7.56]	MRQE 250	198,0 [7.80]	43,5 [1.71]
MR(F) 315	183,0 [7.20]	MRQ 315	189,0 [7.44]	MR(F)E 315	204,0 [8.03]	MRQE 315	210,0 [8.27]	54,8 [2.16]
MR(F) 400	198,0 [7.80]	MRQ 400	204,0 [8.03]	MR(F)E 400	218,0 [8.58]	MRQE 400	224,0 [8.82]	69,4 [2.73]

**MOUNTING**

Oval Mount (2 Holes)

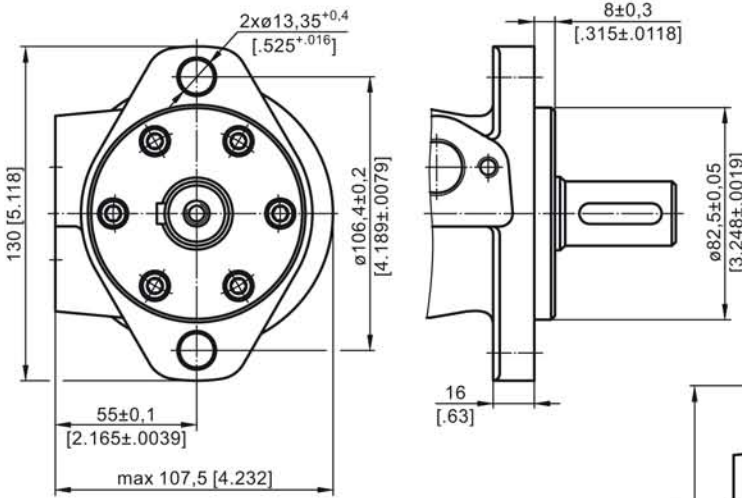

**F** - Oval Mount (4 Holes)

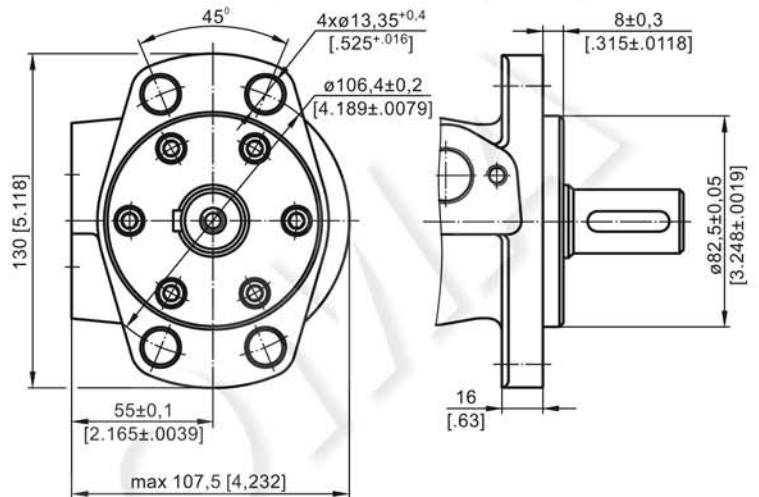

**Q** - Square Mount (4 Bolts)

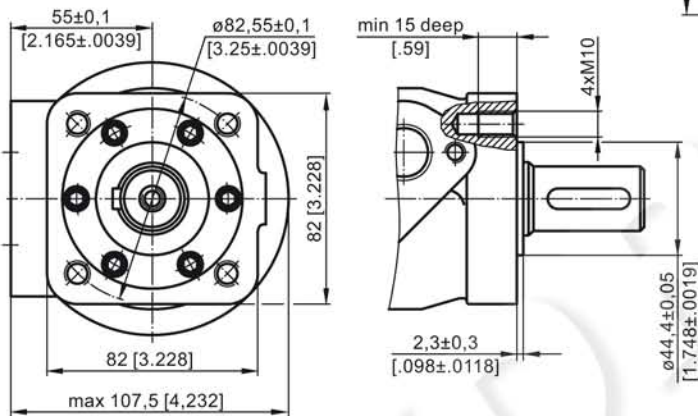

**PORTS**

Side Ports

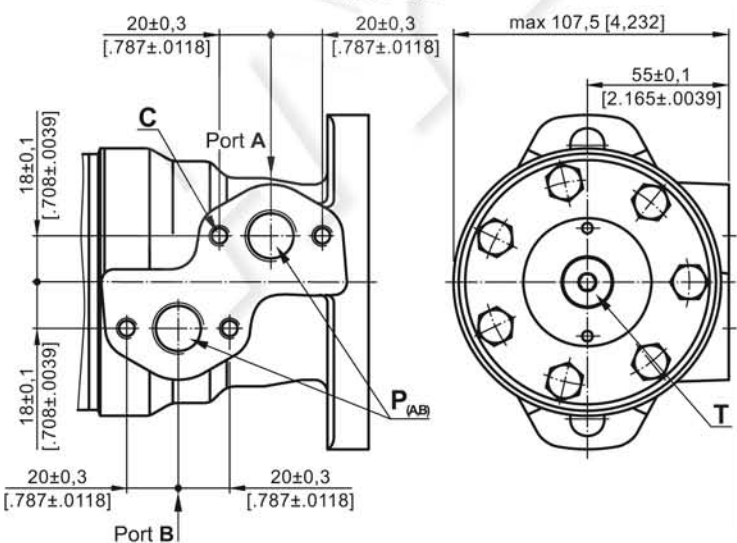

**E** Rear Ports

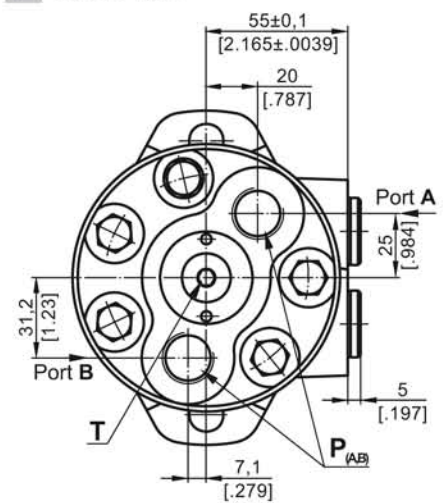

- C** : 4xM8 - 13 mm [0.51 in] depth
- P<sub>(A,B)</sub>** : 2xG1/2 or 2xM22x1,5 - 15 mm [0.59 in] depth
- T** : G1/4 or M14x1,5 - 12 mm [0.47 in] depth (plugged)

**Standard Rotation**  
Viewed from Shaft End  
Port A Pressurized - CW  
Port B Pressurized - CCW

**Reverse Rotation**  
Viewed from Shaft End  
Port A Pressurized - CCW  
Port B Pressurized - CW

**SHAFT EXTENSIONS FOR MP AND MR MOTORS**

**C** -  $\varnothing 25$  straight, Parallel key A8x7x32 DIN 6885  
Max. Torque 34 daNm [3010 lb-in]

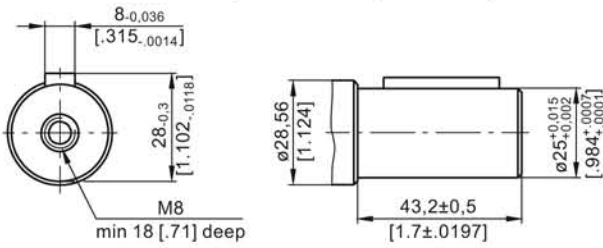

**CB** -  $\varnothing 32$  straight, Parallel key A10x8x45 DIN 6885  
Max. Torque 77 daNm [6815 lb-in]

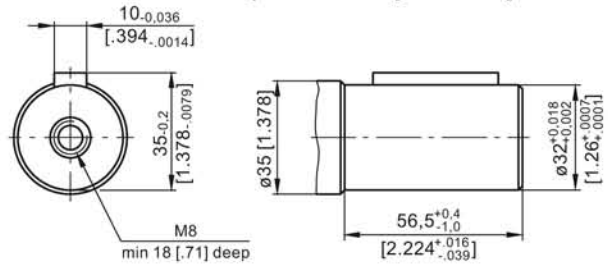

**CO** -  $\varnothing 1$ " straight, Parallel key  $\frac{1}{4}$ "x $\frac{1}{4}$ "x $1\frac{1}{4}$ " BS46  
Max. Torque 34 daNm [3010 lb-in]

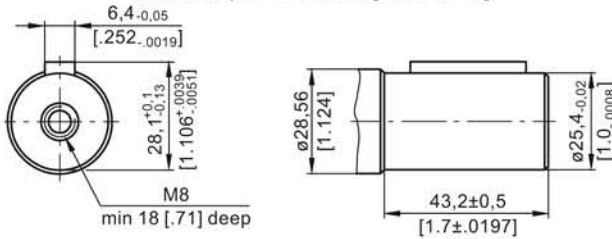

**SB** - splined A25x22xH10 DIN 5482  
Max. Torque 34 daNm [3010 lb-in]

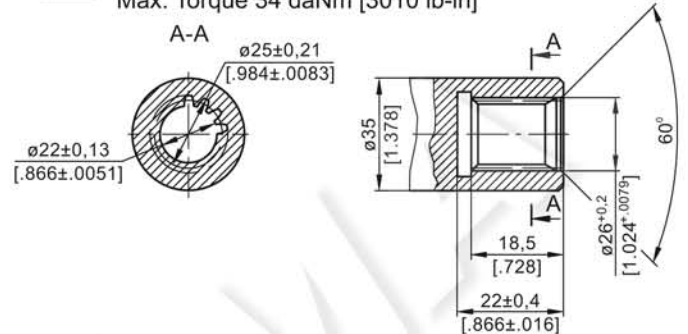

**SH** - splined, BS 2059 (SAE 6B)  
Max. Torque 40 daNm [3540 lb-in]

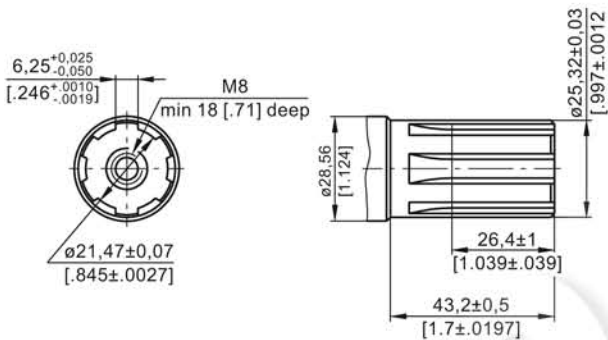

**KB** - tapered 1:10, Parallel key B6x6x20 DIN 6885  
Max. Torque 77 daNm [6815 lb-in]

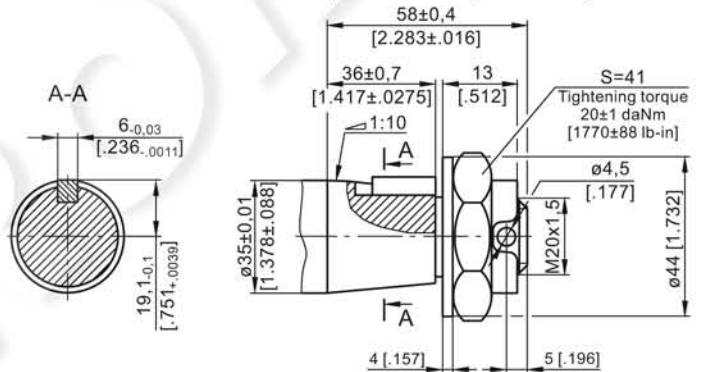

**K** - tapered 1:10, Parallel key B5x5x14 DIN 6885  
Max. Torque 40 daNm [3540 lb-in]

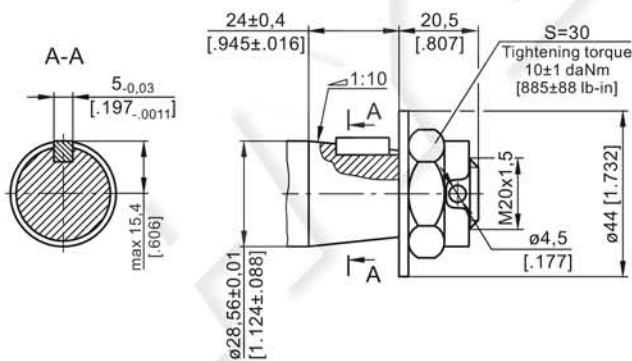

**OB** - tapered 1:8 SAEJ 501, Parallel key  $\frac{5}{16}$ "x $\frac{5}{16}$ "x $1\frac{1}{4}$ " BS46  
Max. Torque 77 daNm [6815 lb-in]

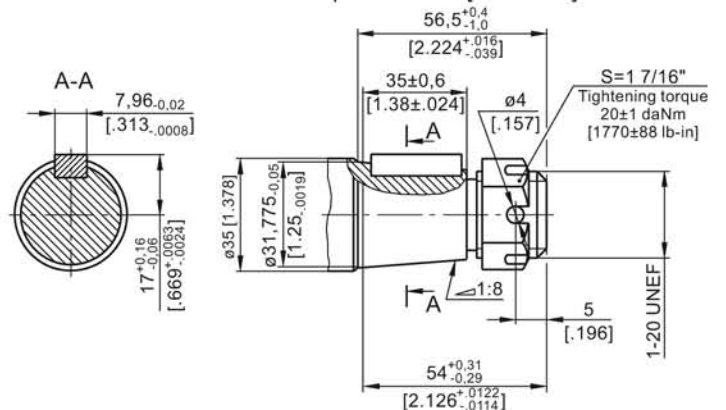

**SA** - splined, B25x22h9 DIN 5482  
Max. Torque 40 daNm [3540 lb-in]

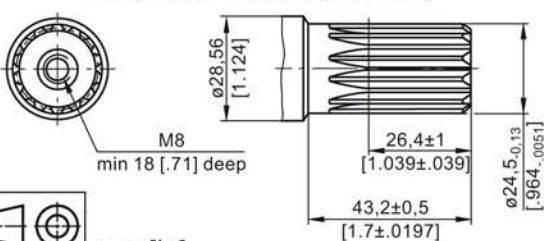

**HB** -  $\varnothing 1\frac{1}{4}$ " splined 14T, ANSI B92.1-1976 Norm  
Max. Torque 77 daNm [6815 lb-in]

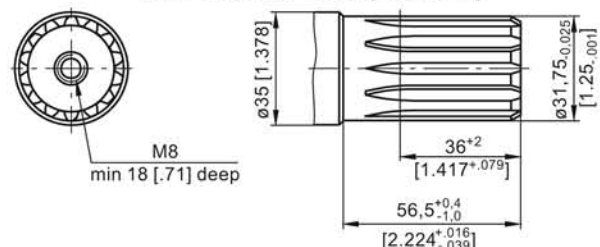

**PERMISSIBLE SHAFT LOADS FOR MP AND MR MOTORS**

The permissible radial shaft load  $P_{rad}$  depends on the speed  $n$ , RPM, distance  $L$  from the point of load to the mounting flange and shaft version.

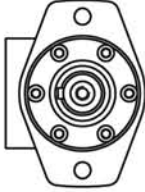
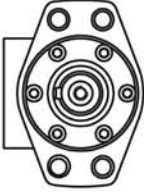
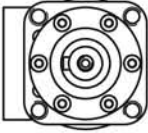
Mounting Flange			
Shaft Version	cylindrical - C, CO tapered - K, splined - SH	splined - HB cylindrical - CB	cylindrical - C, CO
Radial Shaft Load $P_{rad}$ , in mm	$\frac{800}{n} \times \frac{25000}{95+L}$ , daN*	$\frac{800}{n} \times \frac{18750}{95+L}$ , daN*	$\frac{800}{n} \times \frac{25000}{101+L}$ , daN*
Radial Shaft Load $P_{rad}$ , in inch	$\frac{800}{RPM} \times \frac{2215}{3.74+L}$ , lbs*	$\frac{800}{RPM} \times \frac{1660}{3.74+L}$ , lbs*	$\frac{800}{RPM} \times \frac{2215}{3.98+L}$ , lbs*

\*  $n < 200$  RPM; max  $P_{rad}$ =800 daN [1800 lbs]  
 $n \geq 200$  RPM;  $L < 55$  mm [2.2 in]

**MP AND MR**

Radial Shaft Load  $P_{rad}$  for C, CO Shaft Extensions by  $L=30$  mm [1.18 in] (24 mm [.94 in])

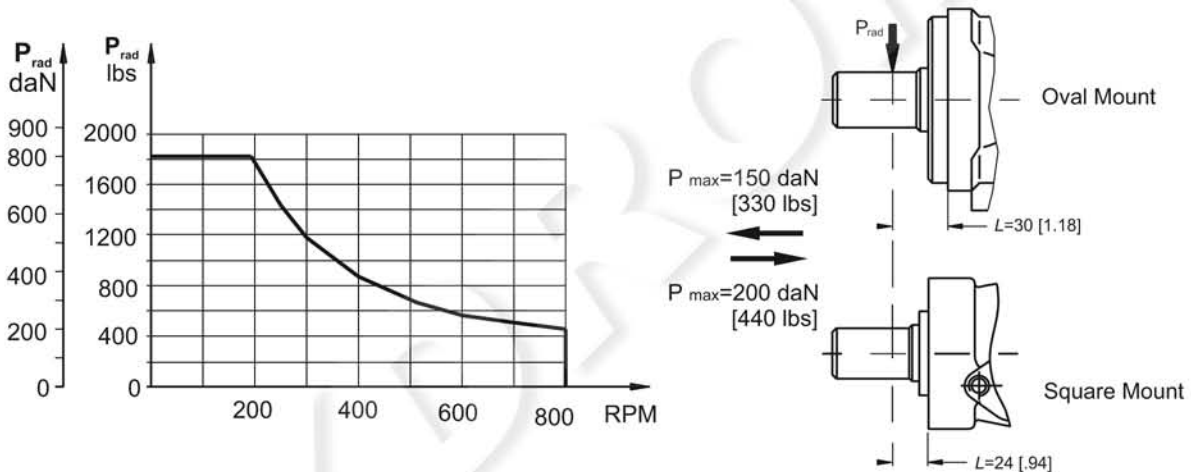

**MPN AND MRN**

The curves apply to a B10 bearing life of 2000 hours.

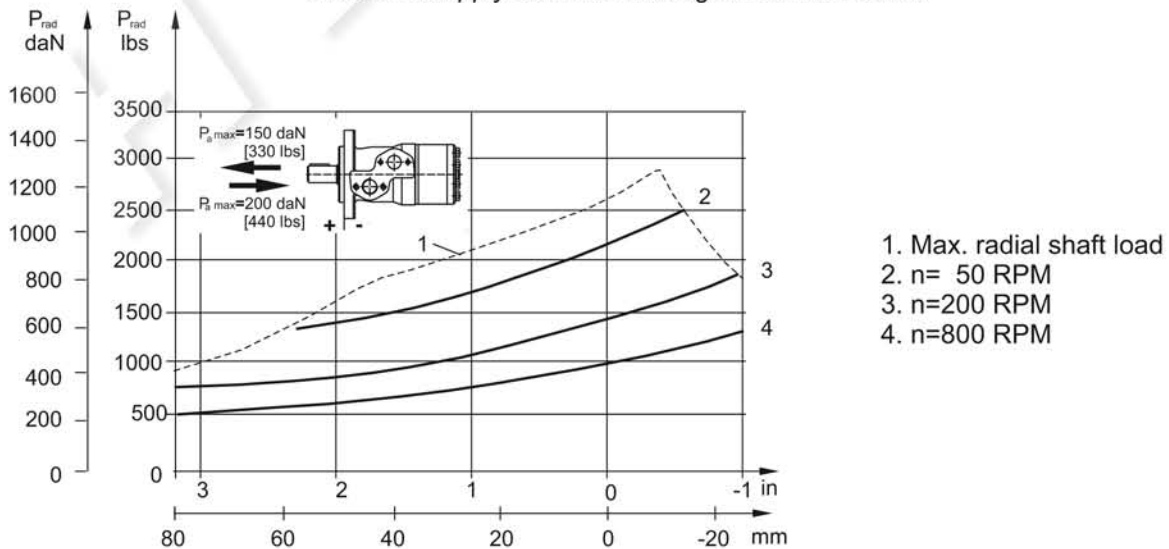

**MAX. PERMISSIBLE SHAFT SEAL PRESSURE FOR MP AND MR MOTORS**

**MP/MR...U1 motors with high pressure seal and without drain connection:**

The shaft seal pressure equals the average of input pressure and return pressure.

$$P_{\text{seal}} = \frac{P_{\text{input}} + P_{\text{return}}}{2}$$

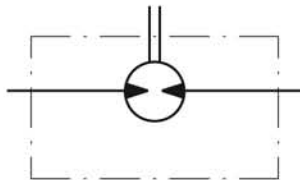

**MP/MR...U motors with high pressure seal and drain connection:**

The shaft seal pressure equals the pressure in the drain line.

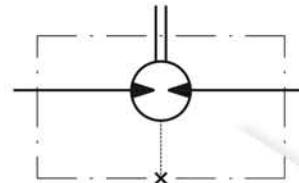

**MP/MR...1 motors with low pressure seal or standard shaft seal and without drain connection:**

The shaft seal pressure never exceeds the pressure in the return line.

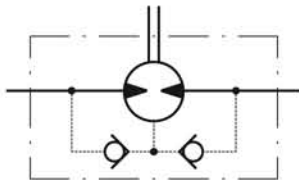

**MP/MR... motors with low pressure seal or standard shaft seal and with drain connection:**

The shaft seal pressure equals the pressure in the drain line.

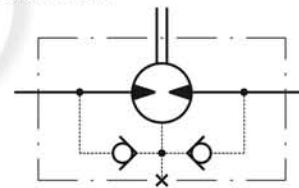

**Max. return pressure without drain line or max. pressure in the drain line**

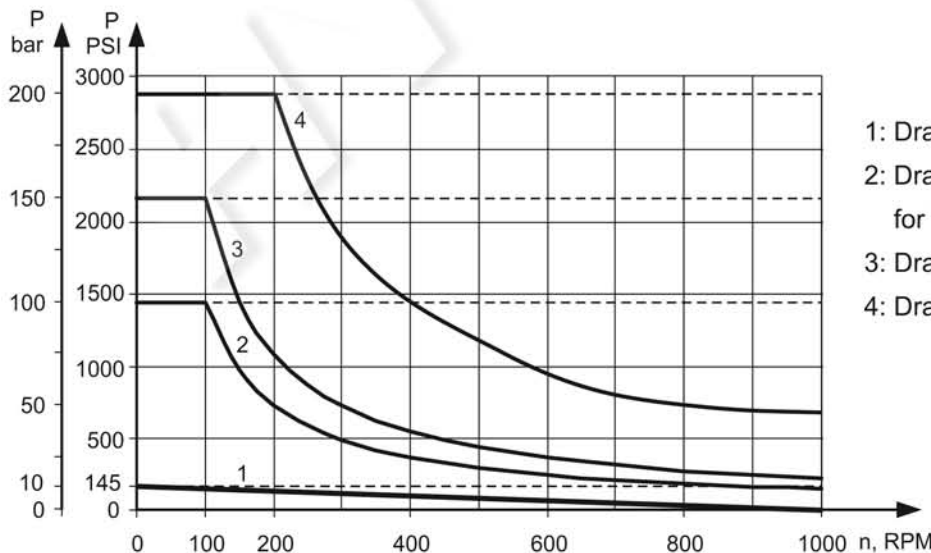

- 1: Drawing for Low Pressure Seal
- 2: Drawing for Standard Shaft Seal for "...B" shafts
- 3: Drawing for Standard Shaft Seal ("D" Seal)
- 4: Drawing for High Pressure Seal ("U" Seal)

— - continuous operations  
- - - - - intermittent operations



## ORDER CODE

	1	2	3	4	5	6	7	8	9	10
<b>MR</b>										

### Pos.1 - Mounting Flange

- omit - Oval mount, two holes
- F** - Oval mount, four holes
- Q** - Square mount, four bolts

### Pos.2 - Option (needle bearings)

- omit - none
- N** - with needle bearings

### Pos.3 - Port type

- omit - Side ports
- E** - Rear ports

### Pos.4 - Displacement code

- 50** - 51,5 cm<sup>3</sup>/rev [ 3.14 in<sup>3</sup>/rev]
- 80** - 80,3 cm<sup>3</sup>/rev [ 4.90 in<sup>3</sup>/rev]
- 100** - 99,8 cm<sup>3</sup>/rev [ 6.09 in<sup>3</sup>/rev]
- 125** - 125,7 cm<sup>3</sup>/rev [ 7.67 in<sup>3</sup>/rev]
- 160** - 159,6 cm<sup>3</sup>/rev [ 9.74 in<sup>3</sup>/rev]
- 200** - 199,8 cm<sup>3</sup>/rev [12.19 in<sup>3</sup>/rev]
- 250** - 250,1 cm<sup>3</sup>/rev [15.26 in<sup>3</sup>/rev]
- 315** - 315,7 cm<sup>3</sup>/rev [19.26 in<sup>3</sup>/rev]
- 400** - 397,0 cm<sup>3</sup>/rev [24.40 in<sup>3</sup>/rev]

### Pos.5 - Shaft Extensions\*

- C** -  $\varnothing$ 25 straight, Parallel key A8x7x32 DIN6885
- VC** -  $\varnothing$ 25 straight, Parallel key A8x7x32 DIN6885 with corrosion resistant bushing
- CO** -  $\varnothing$ 1" straight, Parallel key 1/4"x1/4"x1 1/4" BS46
- VCO** -  $\varnothing$ 1" straight, Parallel key 1/4"x1/4"x1 1/4" Bs46 with corrosion resistant bushing
- SH** -  $\varnothing$ 25,32 splined BS 2059 (SAE 6B)
- VSH** -  $\varnothing$ 25,32 splined BS 2059 (SAE 6B) with corrosion resistant bushing
- K** -  $\varnothing$ 28,56 tapered 1:10, Parallel key B5x5x14 DIN6885
- SA** -  $\varnothing$ 24,5 splined B 25x22 DIN 5482
- VSA** -  $\varnothing$ 24,5 splined B 25x22 DIN 5482 with corrosion resistant bushing
- CB** -  $\varnothing$ 32 straight, Parallel key A10x8x45 DIN6885
- KB** -  $\varnothing$ 35 tapered 1:10, Parallel key B6x6x20 DIN6885
- SB** - splined A 25x22 DIN 5482
- OB** -  $\varnothing$ 1 1/4" tapered 1:8, Parallel key 5/16"x5/16"x1 1/4" BS46
- HB** -  $\varnothing$ 1 1/4" splined 14T ANSI B92.1 - 1976

### Pos. 6 - Shaft Seal Version

- omit - Low pressure shaft seal or Standard shaft seal for "...B" shaft
- D** - Standard shaft seal
- U** - High pressure shaft seal (without check valves)

### Pos. 7 - Drain Port

- omit - with drain port
- 1** - without drain port

### Pos. 8 - Ports

- omit - BSPP (ISO 228)
- M** - Metric (ISO 262)

### Pos. 9 - Special Features

### Pos.10 - Design Series

- omit - Factory specified

**NOTES:** The following combinations are not allowed: - **Q** flange with "...B" shafts;  
 - **N** option with "...B" shafts, Low Pressure Seal or **U** option;  
 - "...B" shafts with **D** and **U** shaft seals.

\* The permissible output torque for shafts must not be exceeded!

The hydraulic motors are manganophosphatized as standard.

# MOTOR SPECIAL FEATURES

Special Feature Description	Order Code	Motor type														
		MM	MP	MPW	MP(W)N	MR	MRN	MRB	SP, SR	PL	RL	PK(Q)	RK	RW	MH	HW
Speed Sensor*	RS	O	O	-	-	O	-	-	-	-	-	-	-	-	O	O*****
Tacho connection	T	-	-	-	-	O	O	-	-	-	-	-	-	-	O	-
Low Leakage	LL	O	-	-	-	O	O	-	-	-	O	-	O	O	O	O
Low Speed Valving	LSV	-	-	-	-	O	-	-	-	-	-	-	-	-	O	O
Free Running	FR	O	O	O	O	O	O	-	-	O	O	O	O	O	O	O
Reverse Rotation	R	O	O	O	O	O	O	O	O	O	O	O	O	O	O	O
Paint**	P	O	O	O	O	O	O	O	O	O	O	O	O	O	O	O
Corrosion Protected Paint**	PC	O	O	O	O	O	O	O	O	O	O	O	O	O	O	O
Special Paint***	PS	O	O	O	O	O	O	O	-	O	O	O	O	O	O	O
	PCS	O	O	O	O	O	O	O	O	O	O	O	O	O	O	O
Check Valves		S	S****	S****	S	S****	S	S	S	S	S	S	S	S****	S****	S

<b>O</b>	Optional
<b>-</b>	Not applicable
<b>S</b>	Standard

- \* For sensor ordering see pages 11÷12
- \*\* Colour at customer's request.
- \*\*\* Non painted feeding surfaces, colour at customer's request.
- \*\*\*\* Without check valves for "U" shaft seal versions.
- \*\*\*\*\* RS option is not available at HW...R (with relief valves).

# MOTORS WITH SPEED SENSOR

## MM...RS

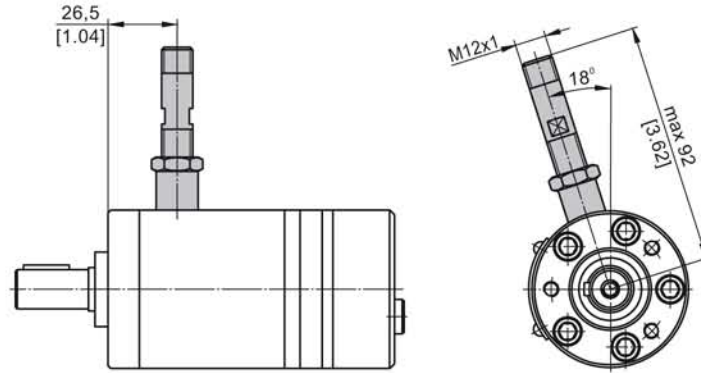

## MP...RS and MR...RS

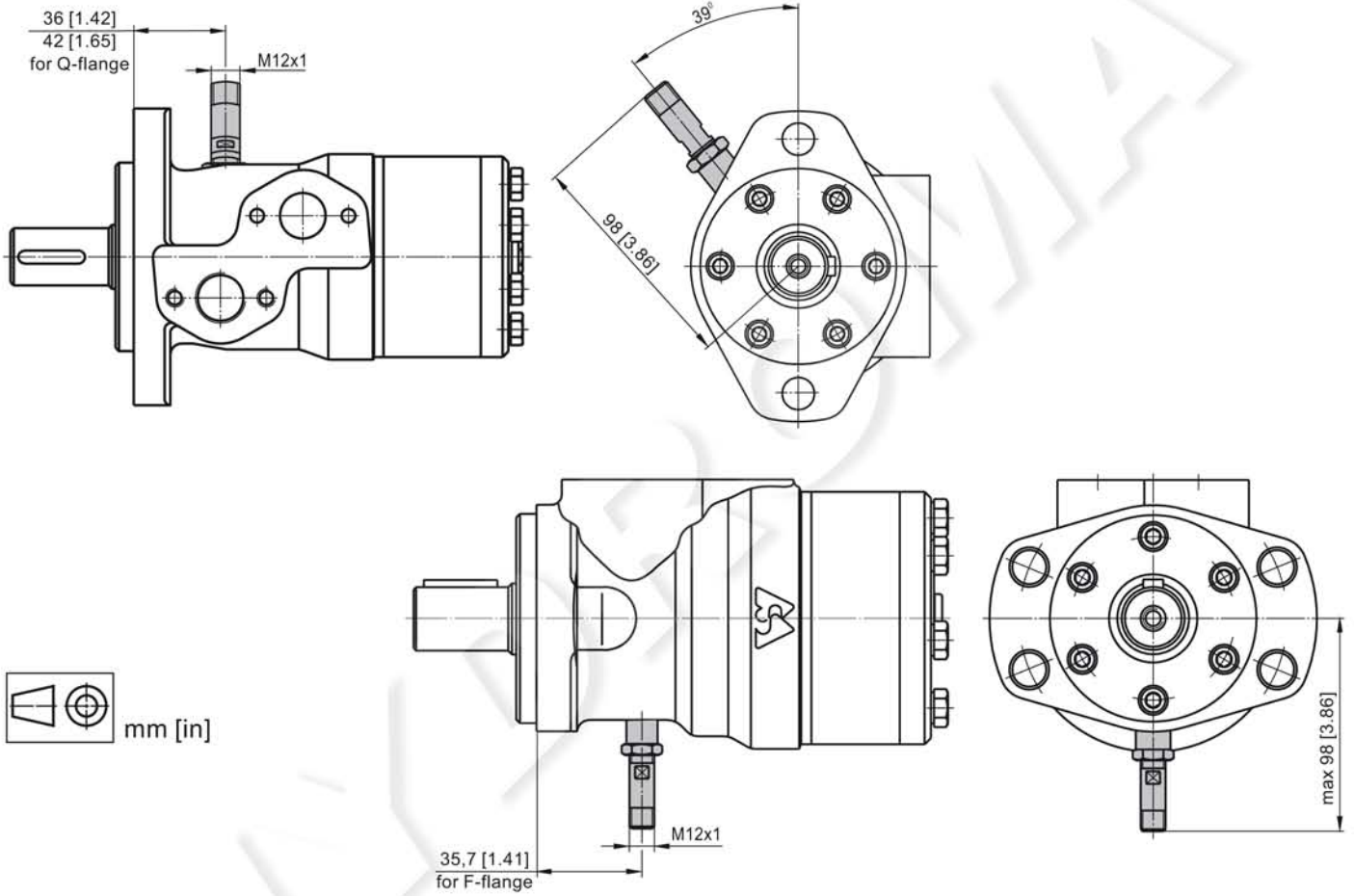

## MH...RS

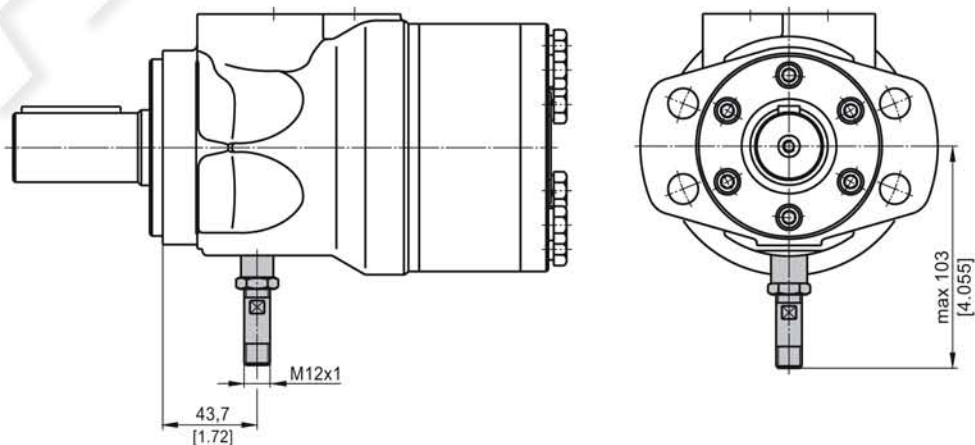

**HW...RS**

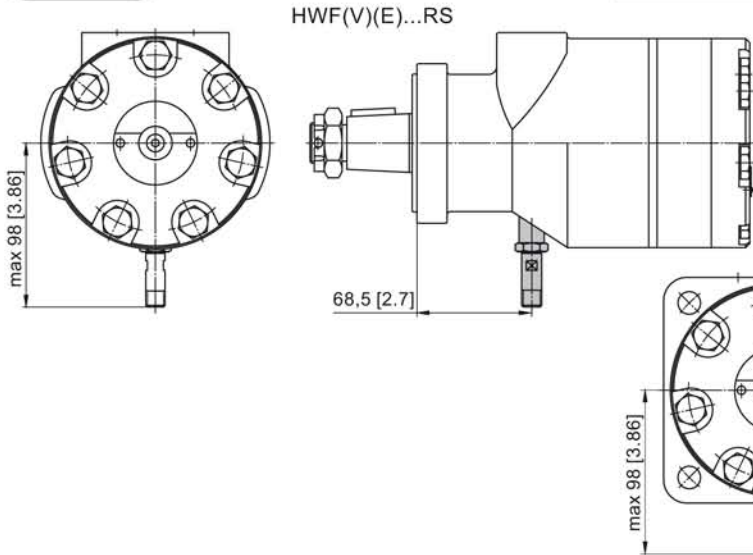

RS option is not available at HW...R (with relief valves).

**HW(S)(D)(SW)(V)(E)...RS**

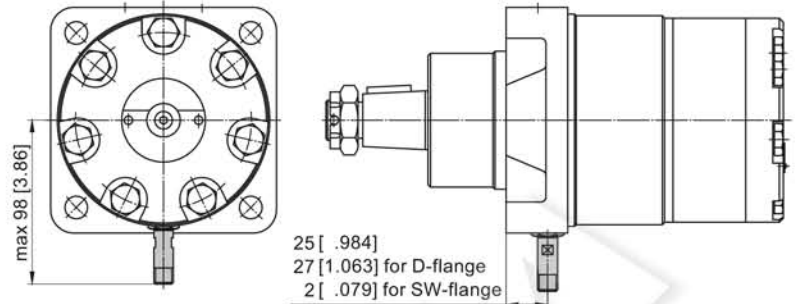

**TECHNICAL DATA OF THE SPEED SENSOR**

**Technical data**

<b>Frequency range</b>	0...15 000 Hz
<b>Output</b>	Universal PUSH PULL
<b>Power supply</b>	10-30 VDC
<b>Current input</b>	<20 mA (@24 VDC)
<b>Maximum output current</b>	500 mA
<b>Ambient Temperature</b>	-40...+125°C [-40...+257°F]
<b>Protection</b>	IP 67
<b>Plug connector</b>	M12-Series
<b>Mounting principle</b>	ISO 6149

**Output signal**

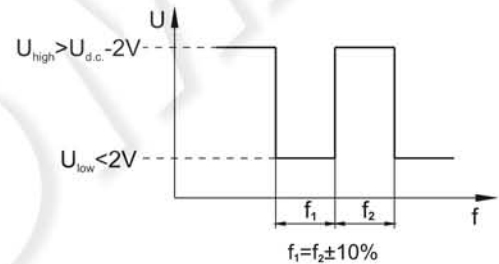

Load max.:  $i_{high} = i_{low} < 50\text{mA}$

Motor type	MM	MP	MR	MH	HW
Pulses per revolution	30	36	36	42	12

**Wiring diagrams**

**PNP**

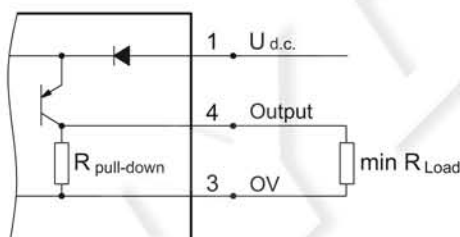

**NPN**

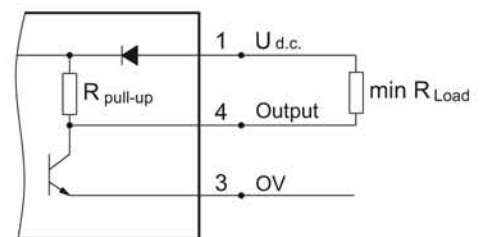

$$R_{Load} [k\Omega] = U_{d.c.} [V] / i_{max} [mA]$$

**Stick type**

**Order Code for Speed Sensor**

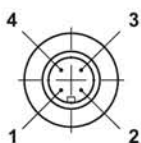

Terminal No.	Connection	Cable Output
1	$U_{d.c.}$	Brown
2	No connection	White
3	0V	Blue
4	Output signal	Black

Sensor Code	Electric connection
<b>RS</b>	Connector BINDER 713 series
<b>RSL2,5</b>	Cable output 3x0,25; 2,5 m [98 in] long
<b>RSL3,5</b>	Cable output 3x0,25; 3,5 m [138 in] long
<b>RSL5</b>	Cable output 3x0,25; 5 m [196 in] long
<b>RSL10</b>	Cable output 3x0,25; 10 m [394 in] long

**NOTE:** \* - The speed sensor is not fitted at the factory, but is supplied in a plastic bag with the motor. For installation see enclosed instructions.