

Part number:

HYDROMA

HYDRAULICKÉ SYSTÉMY

**HIDROMA
SYSTEMS**

UKŁADY HYDRAULICZNE

HYDROMA

ГИДРАВЛИЧЕСКИЕ СИСТЕМЫ

**DIRECTIONAL CONTROL VALVES
MANUAL OPERATED POPPET 2-WAY
NORMALLY CLOSED SPECIAL CAVITY**

VMI-8A-2A-09-NC-S

017-E

OD.55.05.17.37 - Z

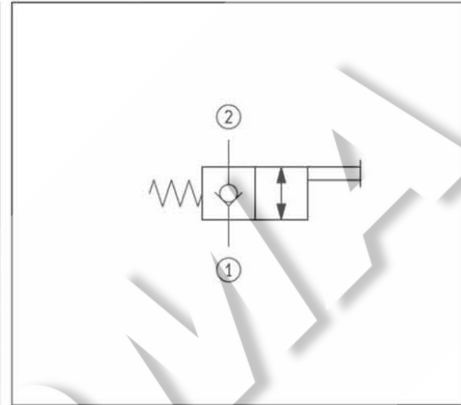
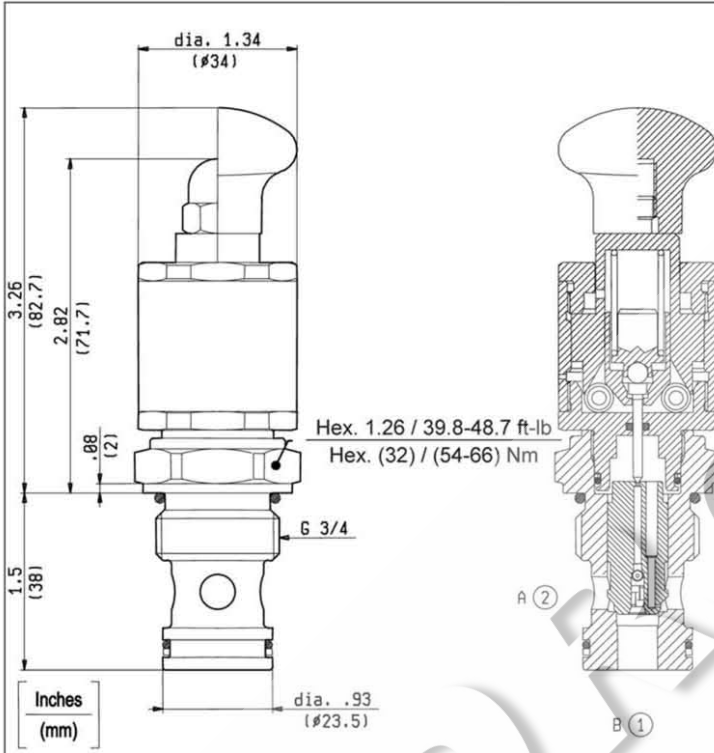

TECHNICAL DATA

Maximum Operating Pressure	5000 psi (350 bar)
Rated Flow	19 gpm (70 l/min)
Cavity - Tooling (017-E)	page CT.S.006.U
Line bodies	page MN2.S...
Weight	0.617 lbs (0.280 kg)
Fluids - Temperatures	page 7.01.040
Testing Conditions - Seals	page 7.01.040
Internal Leakage	page 7.01.040
Filtration : 25 µm nominal or better	page 7.01.050
Mounting Position	unrestricted

Only for cam-operated valves:

OPERATING STROKE: (0.12 in) (3 mm)

MAX. OVERSTROKE: (0.02 in) (0.5 mm)

IMPORTANT: When valve is not operated, flow from 1 to 2 is not recommended due to high opening pressure.

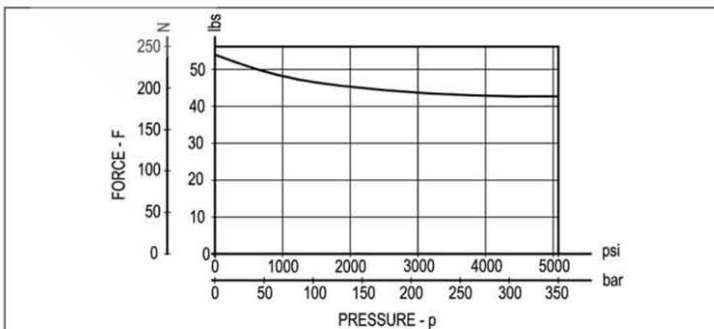
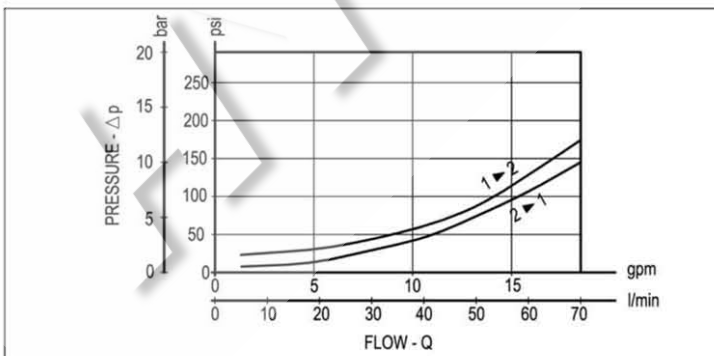

Z	OPERATION	
00	Hand-Operated	
01	Cam-Operated	